

RoHS Compliant

成品图

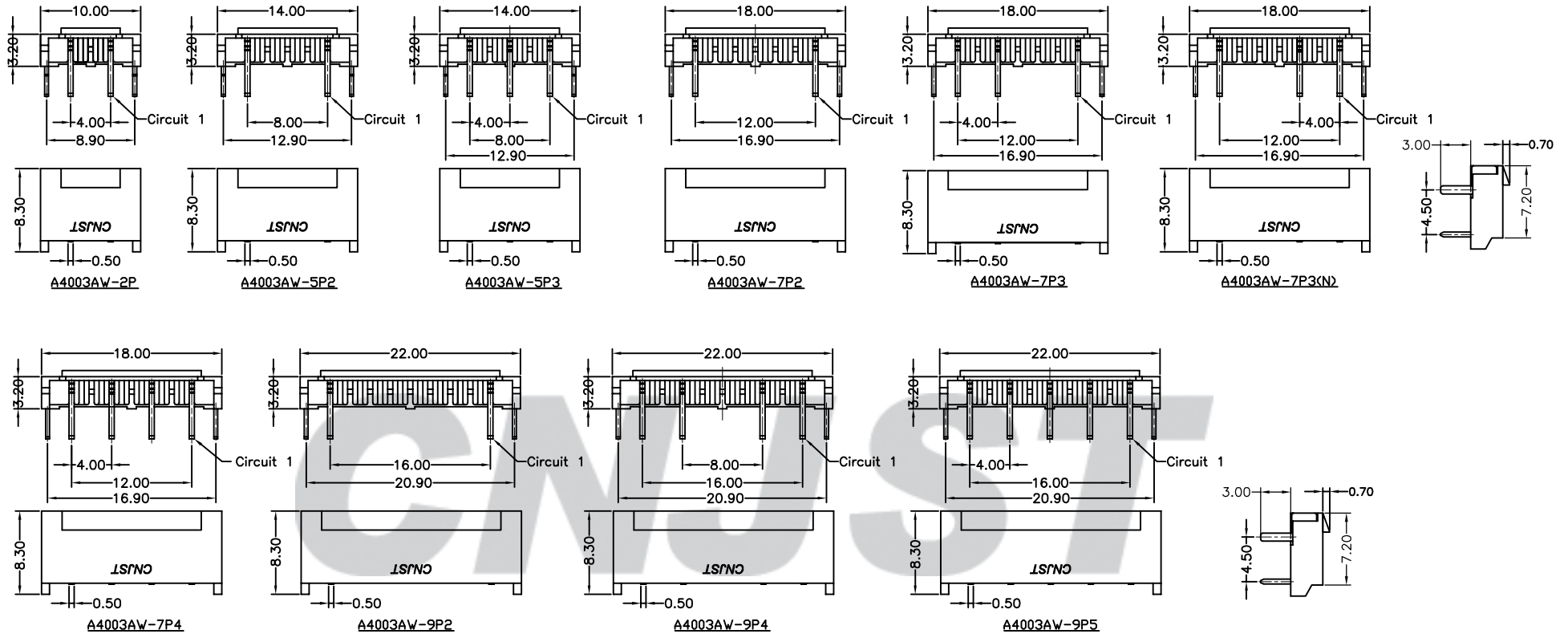

SPECIFICATION

- 1 Contact resistance: $\leq 10m\Omega$
- 2 Insulation resistance: $\geq 1000M\Omega$
- 3 Rated voltage: 600 V AC DC
- 4 Rated current: 1.0 A AC DC
- 5 Withstand Voltage: 1800V AC/minute
- 6 Temperature Range: $-25^{\circ}C \sim +85^{\circ}C$

ORDER INFORMATION:

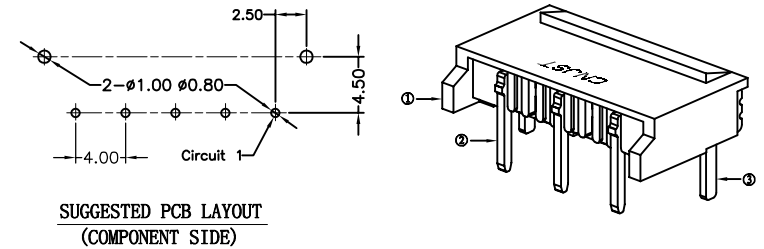
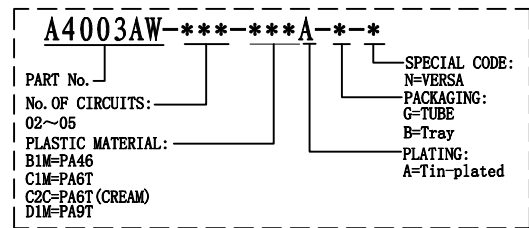

B/O	2016.05.19	NEW RELEASE	
REV.	DATE	DESCRIPTION	APPD.
1			

③	Solder Tabs	2	Phosphor Bronze	Tin-plated
②	Contacts	2~5	Phosphor Bronze	Tin-plated
①	Insulator	1		
NO.	DESCRIPTION	QTY	MATERIAL	PLATING/COLOR

Tolerance	Model Name: 4.00mm PITCH 90° WAFER-DIP TYPE	Drawn: 蔡忠忠 2016. 05. 19
X.X ±0.30	Model No: A4003AW-***-***A-***	
X.XX ±0.20	SCALE: FULL	Checked: 林旭芝
X.XXX ±0.10		REVISION: B/0
Angle ±3.0°		Approved: 刘祚杰
UNIT: mm	CNJST 浙江捷仕泰电子有限公司 ZHEJIANG JIESHITAI ELECTRONIC CO., LTD	DWG NO. CNJST/GCCP-0165