

RoHS Compliant

成品图

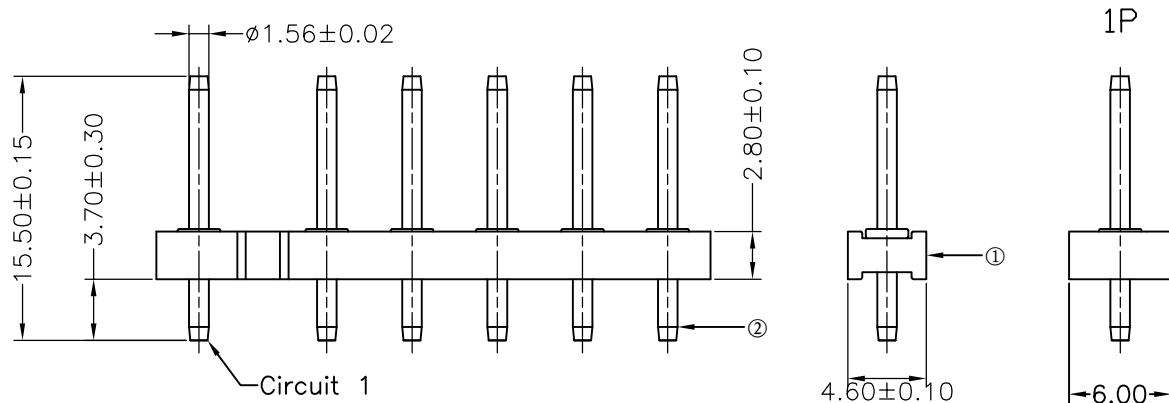

SPECIFICATION

- 1 Contact resistance: $\leq 10m\Omega$
- 2 Insulation resistance: $\geq 1000M\Omega$
- 3 Rated voltage: 250 V AC DC
- 4 Rated current: 5.0 A AC DC
- 5 Withstand Voltage: 1500V AC/minute
- 6 Temperature Range: $-25^{\circ}C \sim +85^{\circ}C$

ORDER INFORMATION:

A7501A--A5WA-P**

| | | | |
|-------------------|--|--|--------------|
| PART No. | | | |
| No. OF CIRCUITS: | | | PACKAGING: |
| 01~06 | | | P=PE |
| PLASTIC MATERIAL: | | | PLATING: |
| A5W=PA66 (WHITE) | | | A=Tin-plated |

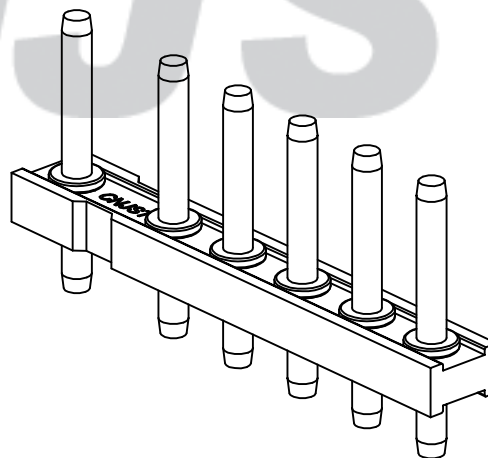
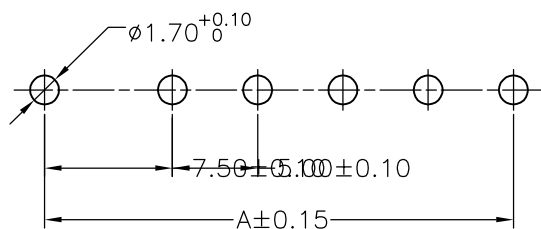
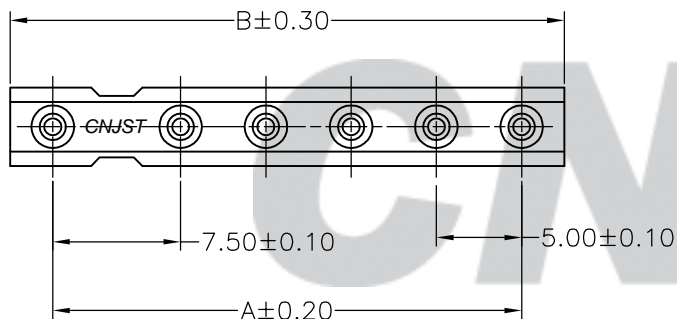

| TYPE-Poles | Dimensions (mm) | |
|------------|-----------------|-------|
| | A | B |
| A7501A-1P | — | 6.00 |
| A7501A-2P | 7.50 | 12.50 |
| A7501A-3P | 12.50 | 17.50 |
| A7501A-4P | 17.50 | 22.50 |
| A7501A-5P | 22.50 | 27.50 |
| A7501A-6P | 27.50 | 32.50 |

SUGGESTED PCB LAYOUT
(COMPONENT SIDE)

| | | |
|---|--|-------------------------|
| Tolerance X.X ± 0.30 X.XX ± 0.20 X.XXX ± 0.10 Angle $\pm 3.0^{\circ}$ | Model Name: 7.50-5.00mm PITCH 180° WAFER | Drawn: 蔡忠忠 2016.05.12 |
| | Model No: A7501A-**-A5WA-P | |
| UNIT: mm | SCALE: FULL | REVISION: B/0 |
| | Checked: 林旭芝 | |
| Approved: 刘祚杰 | | DWG NO. CNJST/GCCP-0117 |
| CNJST 浙江捷仕泰电子有限公司 ZHEJIANG JIESHITAI ELECTRONIC CO., LTD | | |

| REV. | DATE | DESCRIPTION | APPD. | NO. | DESCRIPTION | QTY | MATERIAL | PLATING/COLOR |
|------|------------|-------------|-------|-----|-------------|-----|----------------|---------------|
| B/0 | 2016.05.12 | NEW RELEASE | | ② | Contacts | 1~6 | Brass | Tin-plated |
| | | | | ① | Insulator | 1 | PA66 (UL94V-0) | White |