

RoHS Compliant

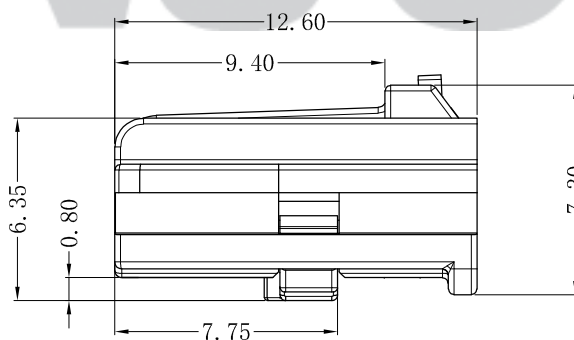
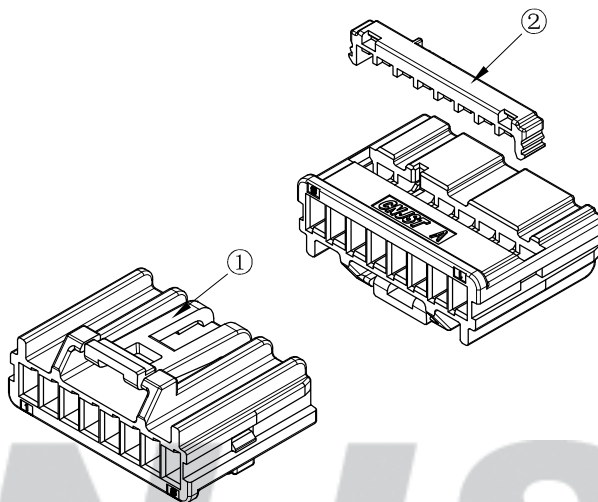
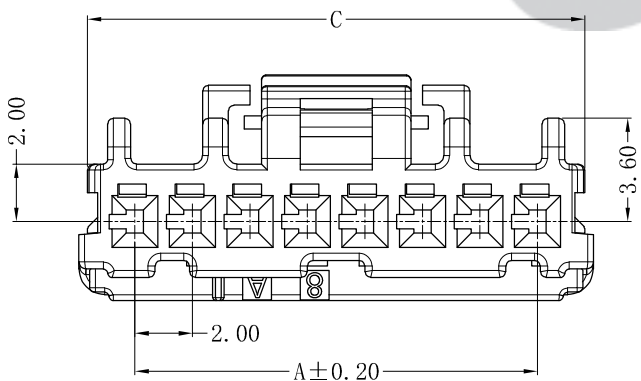
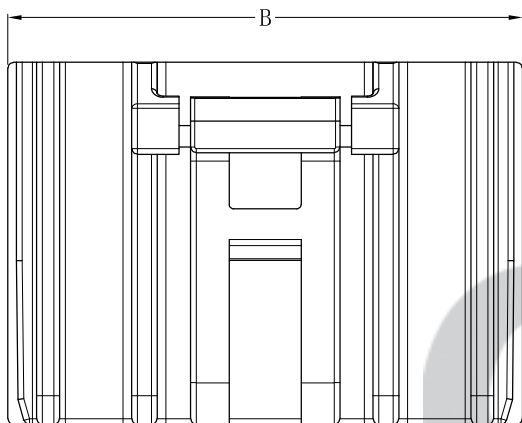
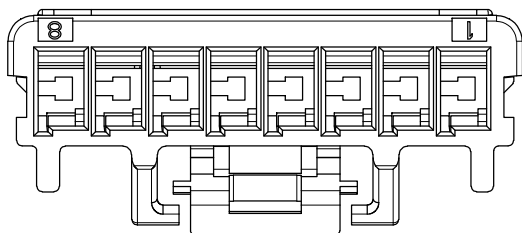

SPECIFICATION

- 1 Contact resistance: $\leq 30m\Omega$
- 2 Insulation resistance: $\geq 100M\Omega$
- 3 Rated voltage: 50 V AC DC
- 4 Rated current: 5.0 A AC DC
- 5 Withstand Voltage: 1000V AC/minute
- 6 Temperature Range: $-40^{\circ}C \sim +125^{\circ}C$

ORDER INFORMATION:

QA2008Y--E1W-B-ZP-A**

PART No.		PACKAGING:	B=TRAY
No. OF CIRCUITS:	02~10	PLASTIC MATERIAL:	E1W=PBT(White)

Circuits	Dimensions (mm)		
	A	B	C
02	2.00	7.90	5.30
03	4.00	9.90	7.30
04	6.00	9.90	9.30
05	8.00	11.90	11.30
06	10.00	13.90	13.30
07	12.00	15.90	15.30
08	14.00	17.90	17.30
09	16.00	19.90	19.30
10	18.00	21.90	21.30

注: 建议客户优先选择我司公母端产品配套使用, 若在没有使用我司公母端配套产品情况下, 出现因产品不匹配的质量问题, 我司将不承担任何风险及责任。

Tolerance X.X ±0.30 X.XX ±0.20 X.XXX ±0.10 Angle ±3.0°	CNJST 捷仕泰企业	Drawn: 黄美程 2023.07.06
	Model No.: QA2008Y-**-E1W-B-ZP-A	Checked: 吴丹平
	Model Name: 2.00mm PITCH HOUSING	Approved: 林旭芝
	UNIT: mm	DWG NO. CNJST/GCCP-0838

REV.	DATE	DESCRIPTION	APPD.	NO.	DESCRIPTION	QTY	MATERIAL	PLATING/COLOR
C/0	2023.07.06	NEW RELEASE	黄美程	②	Locker	1	PBT(UL94V-0)	green
				①	Insulator	1	PBT(UL94V-0)	White

RoHS Compliant

PIN位结构示意图

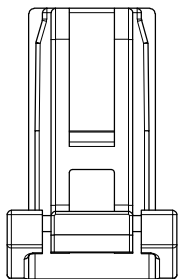

2P

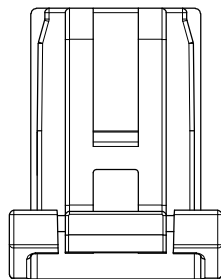

3P

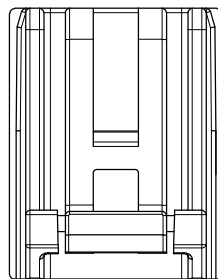

4P

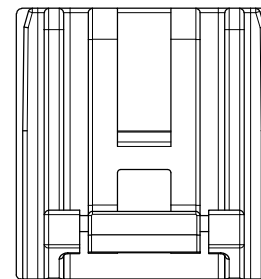

5P

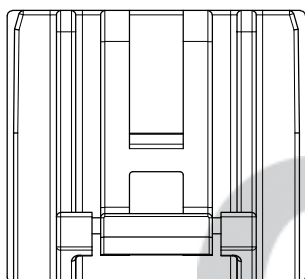

6P

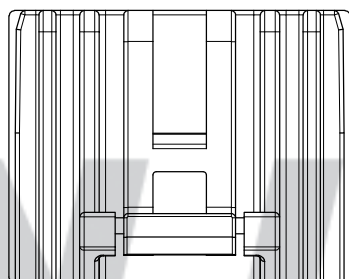

7P

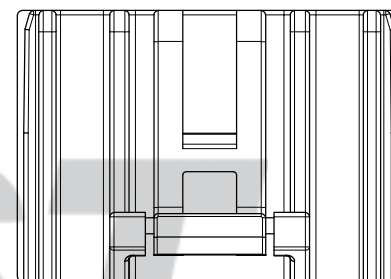

8P

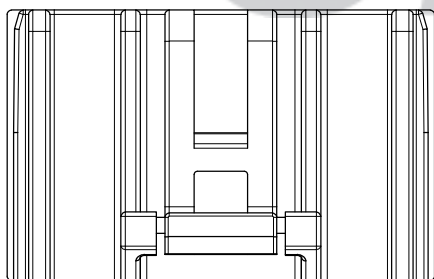

9P

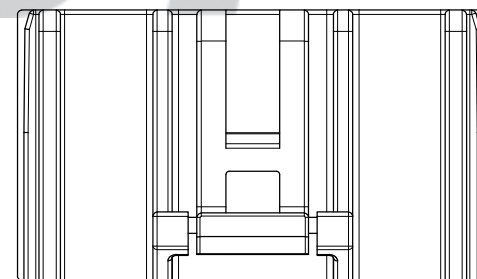

10P

注：建议客户优先选择我司公母端产品配套使用，若在没有使用我司公母端配套产品情况下，出现因产品不匹配的质量问题，我司将不承担任何风险及责任。

Tolerance X.X ±0.30 X.XX ±0.20 X.XXX ±0.10 Angle ±3.0°	CNJST 捷仕泰企业	Drawn: 黄美程 2023.07.06
	Model No.: QA2008Y-**-E1W-B-ZP-A	Checked: 吴丹平
UNIT: mm	Model Name: 2.00mm PITCH HOUSING	Approved: 林旭芝
	 SCALE: FULL REVISION: C/0	DWG NO. CNJST/GCCP-0838

C/0	2023.07.06	NEW RELEASE	黄美程
REV.	DATE	DESCRIPTION	APPD.