

RoHS Compliant

临时图

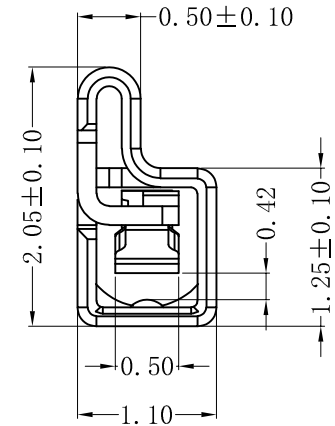

A向
2:1

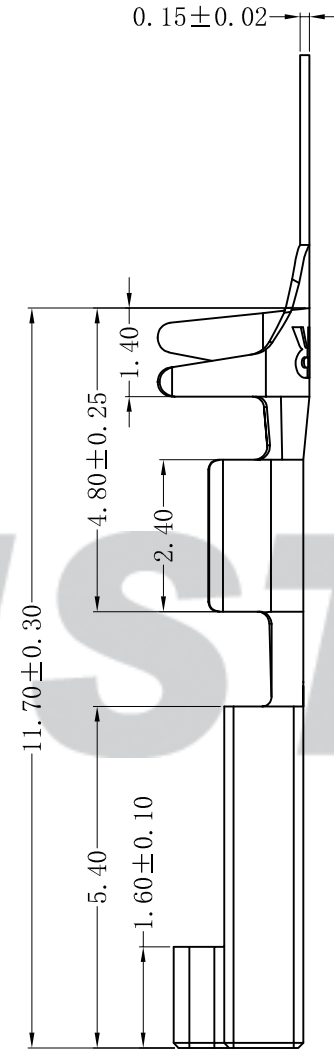
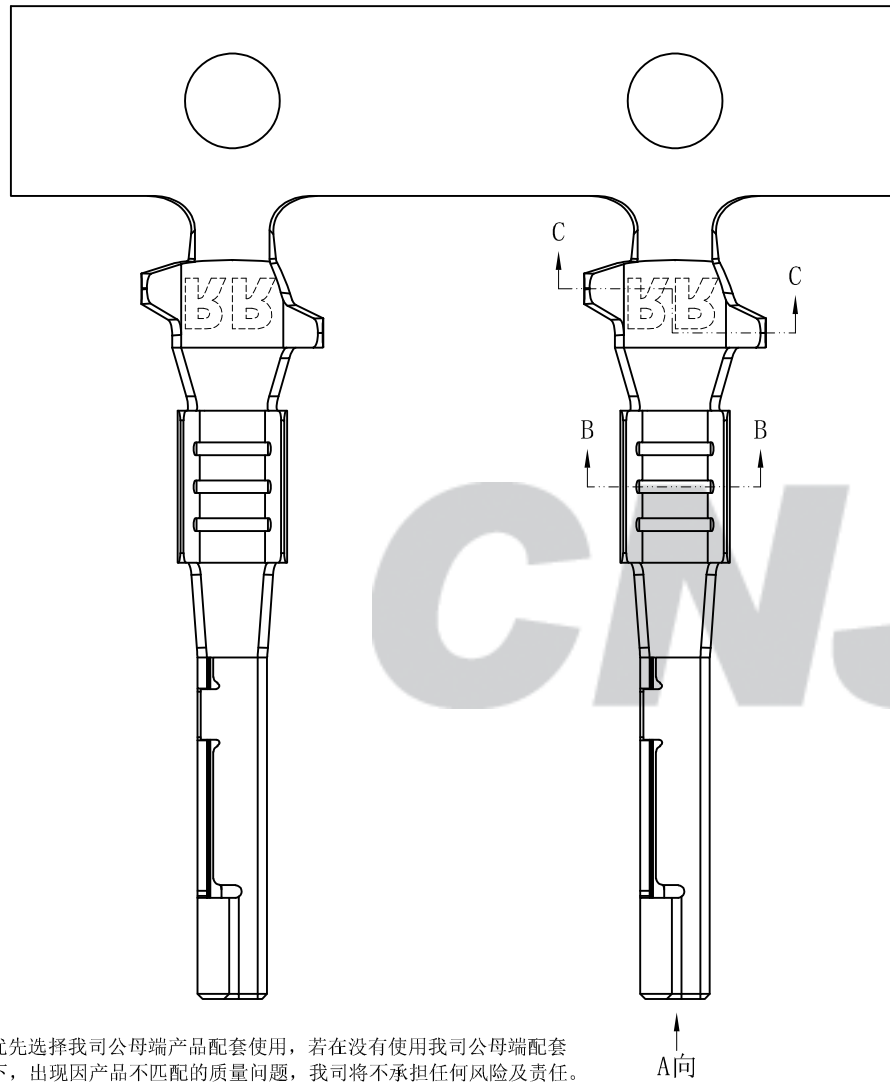
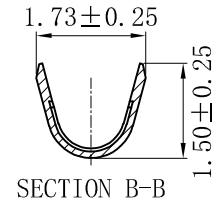

SECTION B-B

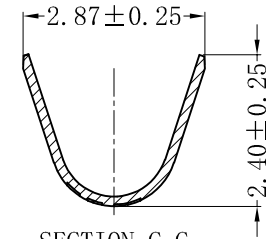

SECTION C-C

注：建议客户优先选择我司公母端产品配套使用，若在没有使用我司公母端配套产品情况下，出现因产品不匹配的质量问题，我司将不承担任何风险及责任。

专利产品

Tolerance
X.X ±0.30
X.XX ±0.20
X.XXX ±0.10
Angle ±3.0°

CNJST 捷仕泰企业

Drawn: 王程伟 2023.05.23

Model No.: QA2007T(SP)-PA-Z

Checked: 吴丹平

Model Name: 2.00mm PITCH CRIMP TERMINAL

Approved: 林旭芝

UNIT: mm

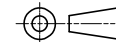

SCALE: FULL

REVISION: C/0

DWG NO. CNJST/GCDZ-0832

REV.	DATE	DESCRIPTION	APPD.	Wire Range	Insulation O.D.	QTY/Reel	Material	Plating
C/0	2023.05.23	NEW RELEASE		AWG #22	1.50mm (Max)	10,000Pcs	Phosphor Bronze	Tin-plated