

RoHS Compliant

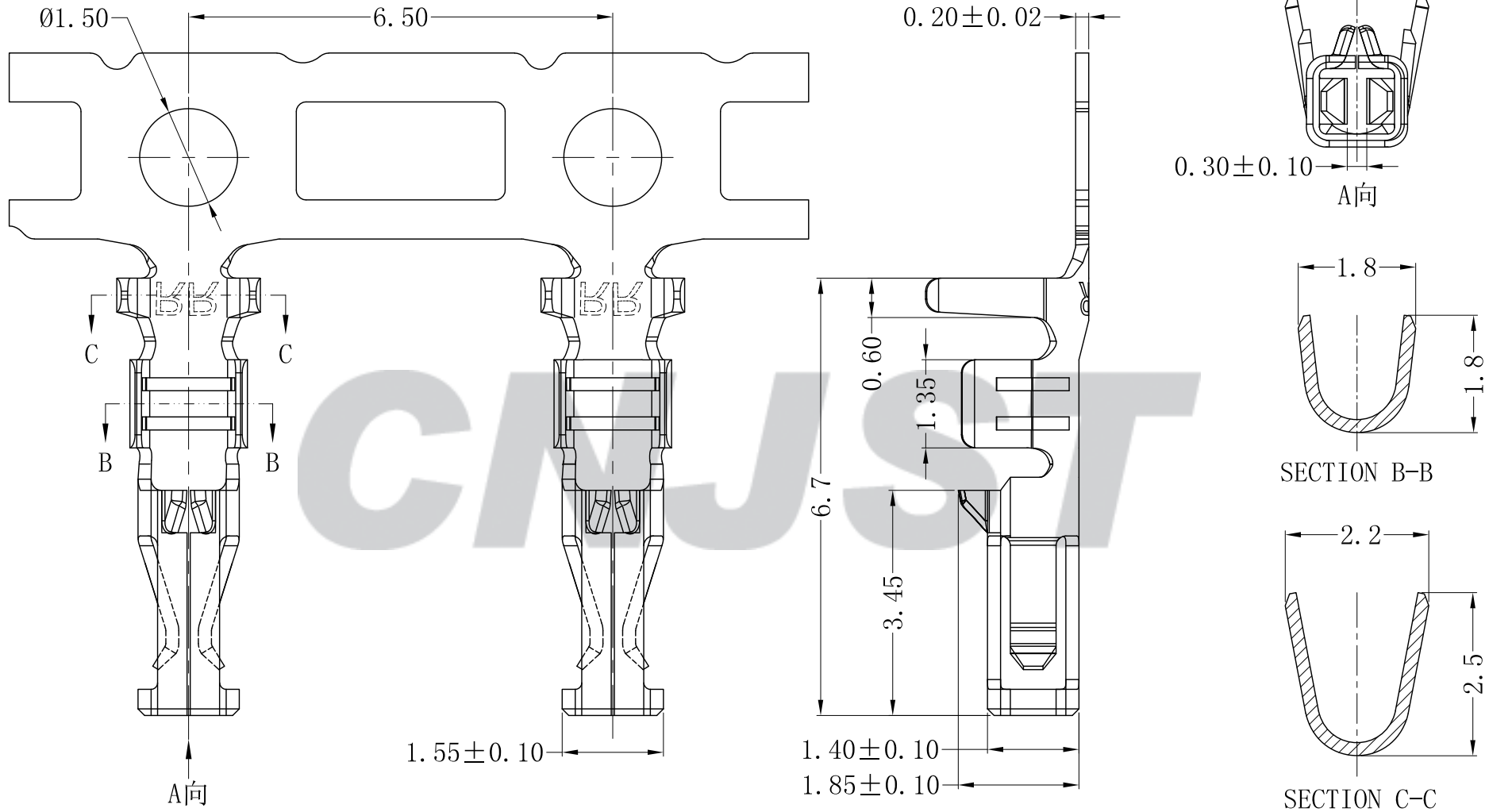

注：建议客户优先选择我司公母端产品配套使用，若在没有使用我司公母端配套产品情况下，出现因产品不匹配的质量问题，我司将不承担任何风险及责任。

专利产品

									Tolerance		CNJST 捷仕泰企业	Drawn: 王程伟 2022.10.19		
									X.X ±0.30			Model No.: QA2005TH-PA-Z		Checked: 吴丹平
									X.XX ±0.20		Model Name: 2.00mm PITCH CRIMP TERMINAL		Approved: 林旭芝	
									X.XXX ±0.10		UNIT: mm		SCALE: FULL REVISION: C/0	
									Angle ±3.0°					
C/O	2022.10.19	NEW RELEASE		AWG #20~#24	1.60mm (Max)	10,000PCS	Phosphor Bronze	Tin-plated						
REV.	DATE	DESCRIPTION	APPD.	Wire Range	Insulation O.D.	QTY/Reel	Material	Plating						