

RoHS Compliant

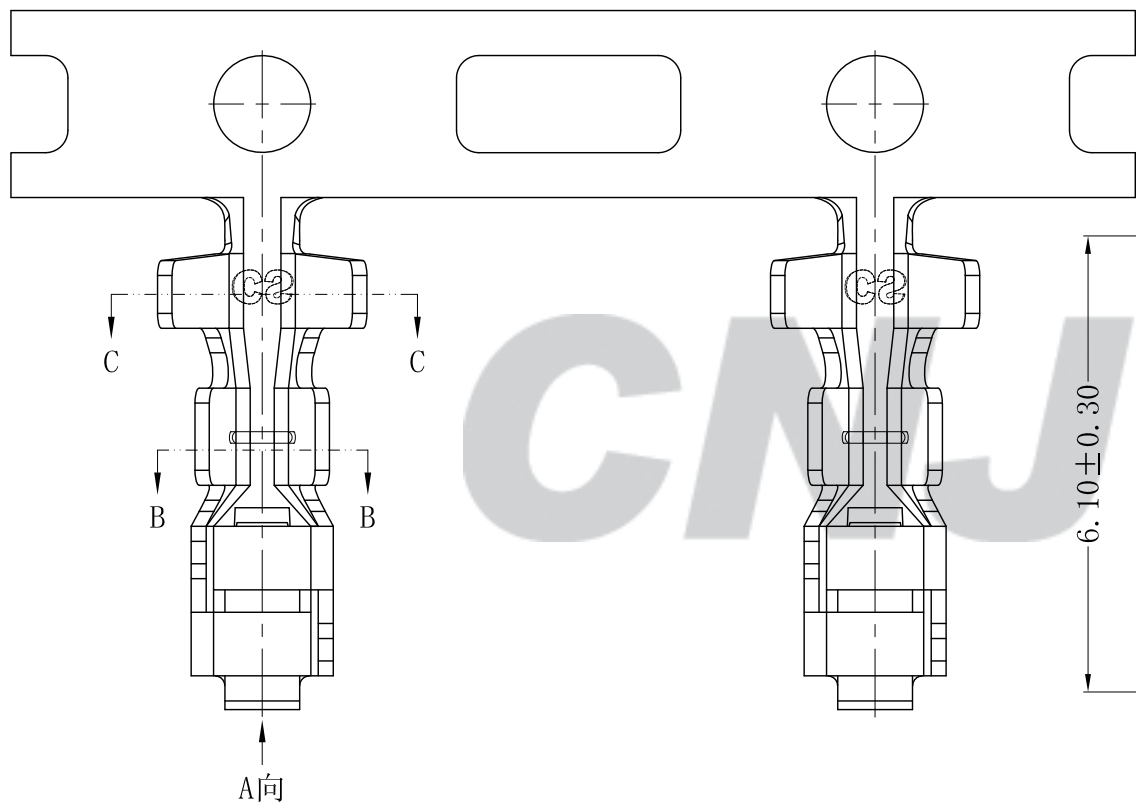

0.20 ± 0.02

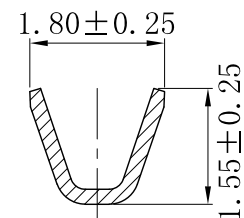
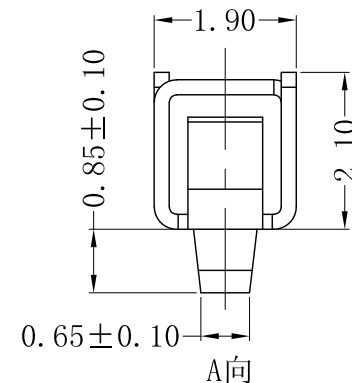
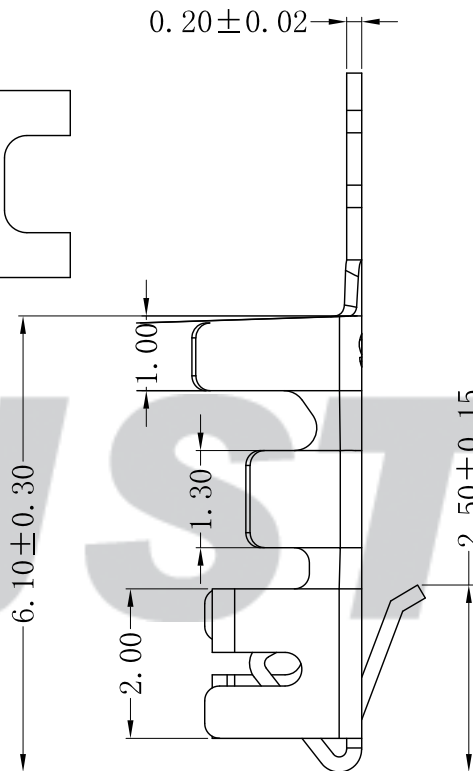

SECTION B-B

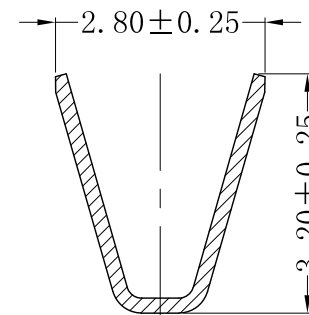

SECTION C-C 专利产品

REV.	DATE	DESCRIPTION	APPD.	Wire Range	Insulation O.D.	QTY/Reel	Material	Plating
C/0	2022.11.14	更新图框	王程伟					
B/1	2018.01.20	NEW RELEASE		AWG #22~#28	1.90mm (Max)	7,000PCS	Phosphor Bronze	Tin-plated

Tolerance	
X.X	±0.30
X.XX	±0.20
X.XXX	±0.10
Angle	±3.0°

UNIT: mm

CNJST 捷仕泰企业

Model No.: A2502T-PA-Z

Model Name: 2.50mm PITCH CRIMP TERMINAL

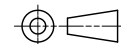

SCALE: FULL

REVISION: C/0

Drawn: 王程伟 2022.11.14

Checked: 吴丹平

Approved: 林旭芝

DWG NO. CNJST/GCDZ-0013