

RoHS Compliant

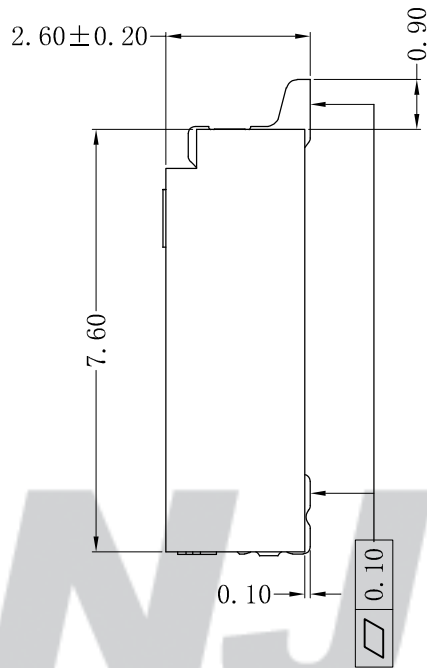
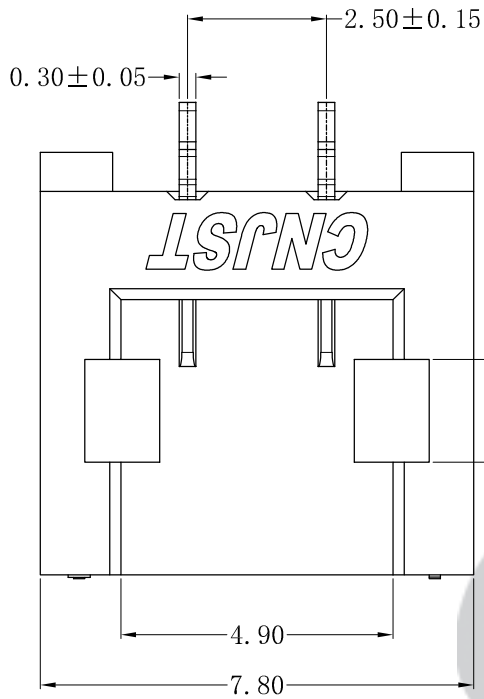

SPECIFICATION

- 1 Contact resistance: $\leq 30m\Omega$
- 2 Insulation resistance: $\geq 1000M\Omega$
- 3 Rated voltage: 250 V AC DC
- 4 Rated current: 1 A AC DC
- 5 Withstand Voltage: 1000V AC/minute
- 6 Temperature Range: $-25^{\circ}C \sim +85^{\circ}C$

ORDER INFORMATION:

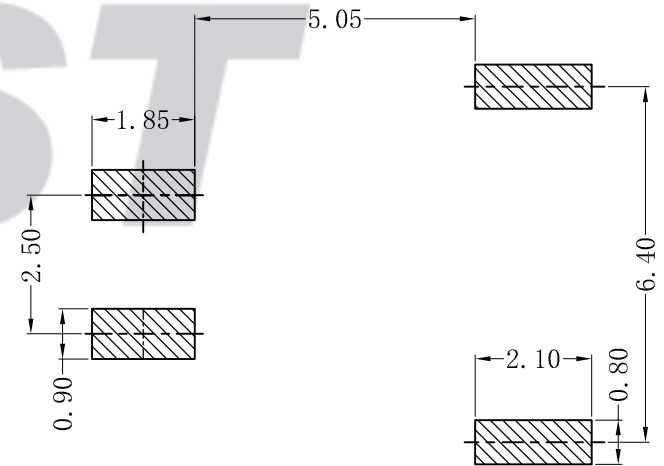
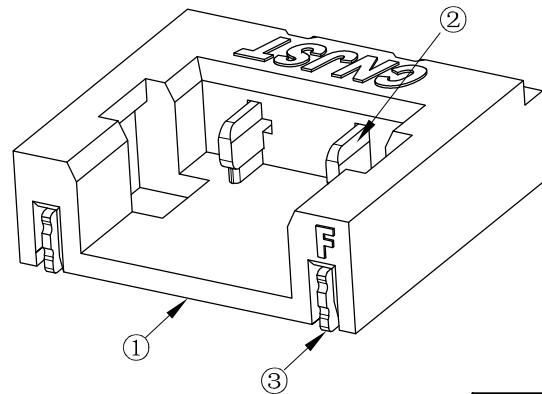
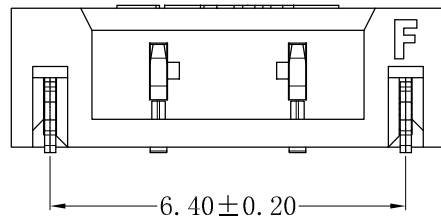
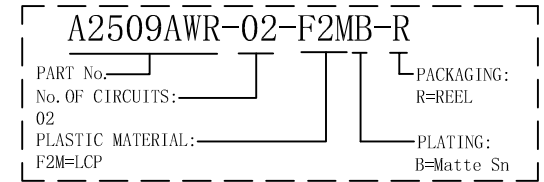

SUGGESTED PCB LAYOUT
(COMPONENT SIDE)

专利产品

REV.	DATE	DESCRIPTION	APPD.	NO.	DESCRIPTION	QTY	MATERIAL	PLATING/COLOR
C/0	2022.12.07	统一标准 更新模版	黄羨程	③	Solder Tab	2	Phosphor Bronze	Matte Sn
B/0	2018.08.21	NEW RELEASE	王炜彬	②	Material	2	Phosphor Bronze	Matte Sn
				①	Insulator	1	LCP(UL94V-0)	Nature

Tolerance	X.X ±0.30
	X.XX ±0.20
	X.XXX ±0.10
Angle	±3.0°
UNIT:	mm

CNJST 捷仕泰企业	
Model No.: A2509AWR-02-F2MB-R	
Model Name: 2.50mm pitch 90° WAFER-SMT TYPE	
	SCALE: FULL
REVISION: C/0	

Drawn: 黄羨程 2022.12.07
Checked: 吴丹平
Approved: 林旭芝
DWG NO.: CNJST/GCCP-0524