

RoHS Compliant

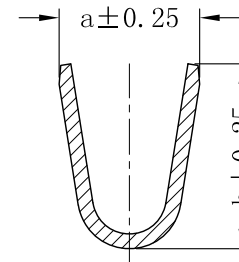

SECTION A-A

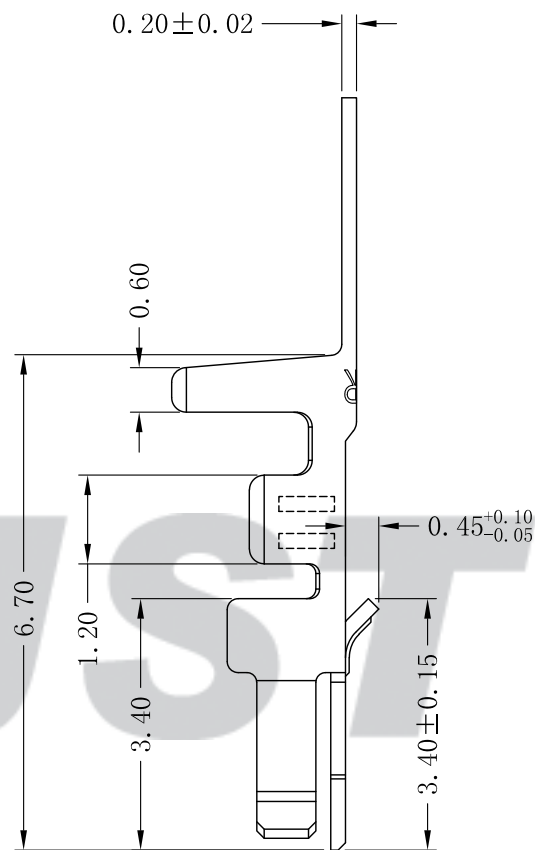
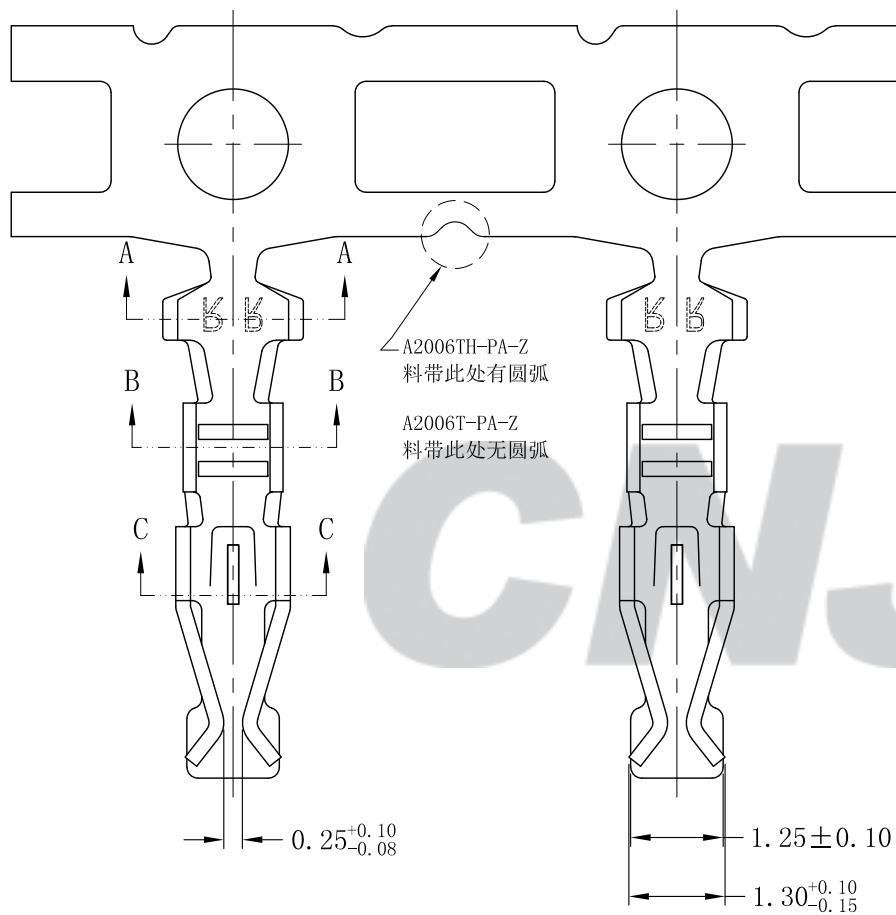
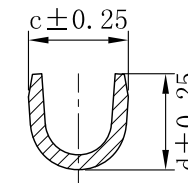

SECTION B-B

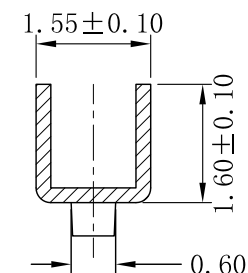

SECTION C-C

Model No	Dimensions (mm)			
	a	b	c	d
A2006TH-PA-Z	2.20	2.50	1.80	1.80
A2006T-PA-Z	1.90	2.50	1.38	1.50

专利产品

REV.	DATE	DESCRIPTION	APPD.	Model No	Wire Range	Insulation O.D.	QTY/Reel	Material	Plating
C/0	2022.07.19	更新图框	王程伟	A2006TH-PA-Z	AWG #20~#24	1.60mm (Max)	10,000PCS	Phosphor Bronze	Tin-plated
B/1	2020.11.19	NEW RELEASE		A2006T-PA-Z	AWG #22~#28	1.60mm (Max)	10,000PCS	Phosphor Bronze	Tin-plated

Tolerance	
X.X	±0.30
X.XX	±0.20
X.XXX	±0.10
Angle	±3.0°

CNJST 捷仕泰企业	
Model No. A2006T/A2006TH-PA-Z	
Model Name: 2.00mm PITCH CRIMP TERMINAL	

Drawn: 王程伟 2022.07.19
Checked: 吴丹平
Approved: 林旭芝
DWG NO. CNJST/GCDZ-0007

UNIT: mm

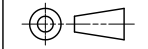

SCALE: FULL REVISION: C/0