

RoHS Compliant

端子图

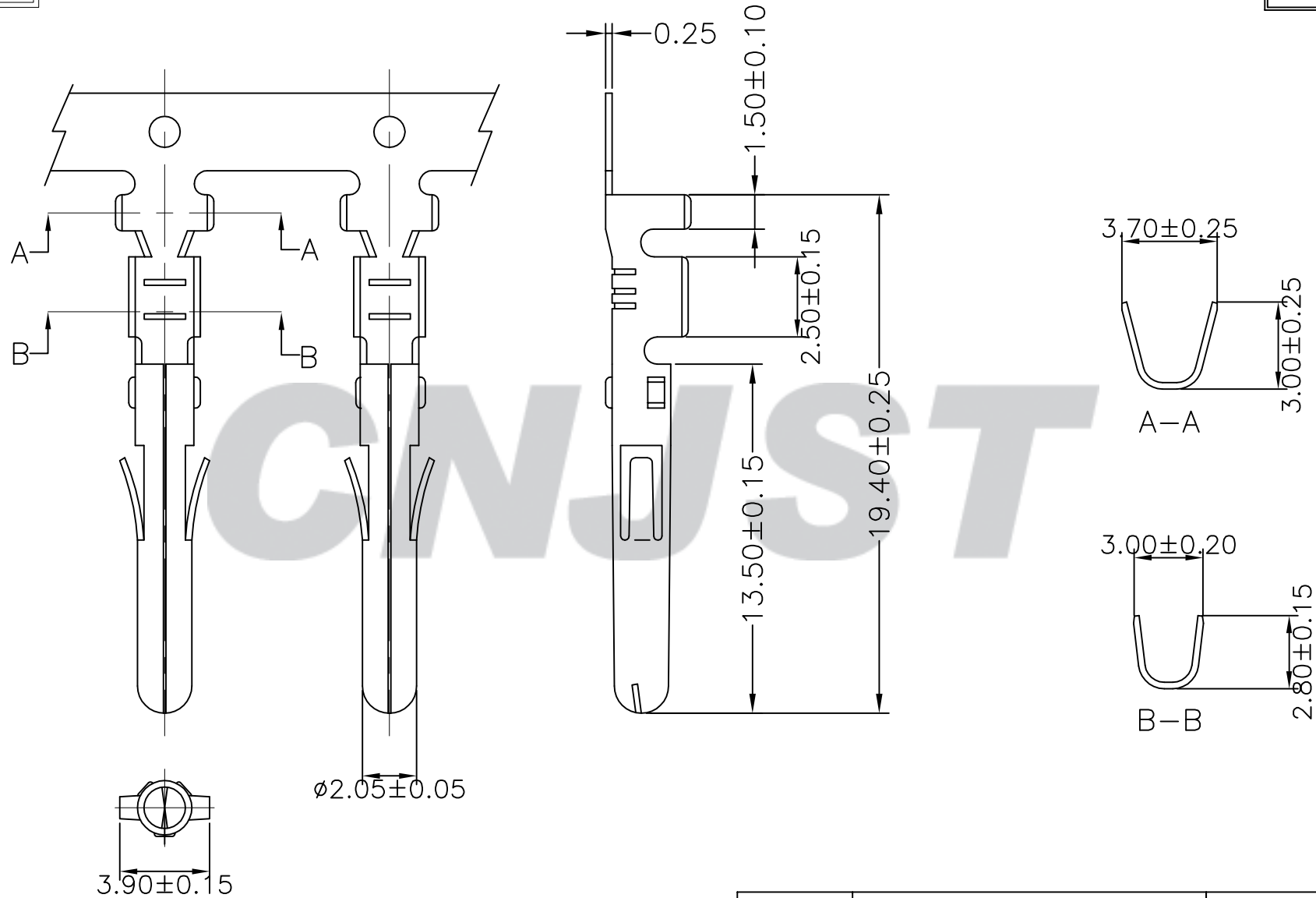
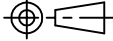

Tolerance X.X ±0.30 X.XX ±0.20 X.XXX ±0.10 Angle ±3.0°	Model Name: 5.08mm PITCH CRIMP TERMINAL		Drawn: 张育斌 2016.06.13
	Model No: C5081PT-*A-Z		
	SCALE: FULL	REVISION: B/1	Checked: 林旭芝
	<b>CNJST</b> 浙江捷仕泰电子有限公司 ZHEJIANG JIESHITAI ELECTRONIC CO., LTD		Approved: 刘祚杰
UNIT: mm			DWG NO. CNJST/GCDZ-0054

REV.	DATE	DESCRIPTION	APPD.	Part No	Wire Range	Insulation O.D.	QTY/Reel	Material	Plating
				C5081PT-BA-Z	AWG #18~#22	2.30mm(max)	7,000Pcs	Brass	Tin-plated
				C5081PT-PA-Z	AWG #18~#22	2.30mm(max)	7,000Pcs	Phosphor Bronze	Tin-plated
2016.06.13		NEW RELEASE							